

Packaging and palletizing for vegetables



since 1916

Semi Automatic Packaging

EMVE produce a wide range of simple solutions for small and high capacities.



Packaging and sealing 0,5 – 5 kg



Processed vegetables etc. 5 – 25 kg



For sack and box
5 – 300 kg

Fully Automatic Lines



Packaging in v-film
plastic 0,2 – 25 kg



Paperbagger
1 – 10 kg

Verticalbagger for
plasticbag 0,1 – 7 kg



EMVE delivers complete lines for packaging in paper, plastic, net and tray. Capacity up to 100/min.

Flowpack lines.



Weighing System



Multi-head weigher for vegetables, fruits and berries.

Weigher and netbaggers, capacity up to 100/min.

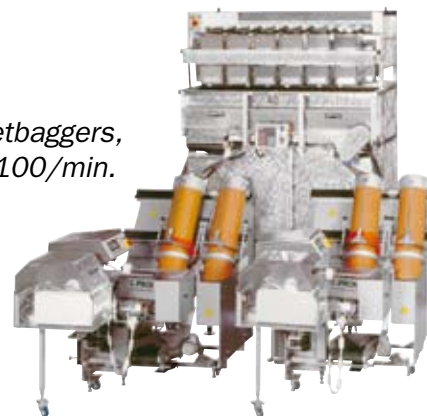

EMVE integrates various types of weighing systems for optimal solutions.

Multi-head weigher for compact solutions with high capacity.



Palletizing and Transport



Rib conveyor for trays, bags and boxes.

EMVE automize packaging and palletizing in the vegetable and food industry. Palletizing systems can be supplied according to individual requirements.



Robot palletizing of sacks, cardboard –or plastic boxes etc.



Depalletizing of plastic boxes.



Checkweighers and metal detectors.

EMVE can supply more

Receiving



Grading



Polishing



Washing



Storing



Electronics and automation



EMVE business concept

EMVE shall be a flexible producer and supplier, and shall very fast solve the needs of the customers, concerning business and processing of potatoes and similar food products, through delivery of complete systems or separate equipment.

Characteristic for the products shall be, customer adaptation, rational and careful solution with high quality and modern engineering together with a good service.

Good ethics in business- and customer relationship are prestige words for EMVE.

