

Weigher W-5

For weighing potatoes, onions etc in 0,5–5 kg batches



W-5 with single scale.

These weighers are intended for weighing potatoes, onions and other similar products in batches of 0,5-5 kg 10 kg at the double weigher. They are available in different versions, featuring single or double scales.

The separate fine and coarse feed

with individually adjustable vibration and pneumatic damper make for accurate yet rapid weighing into predefined batch weights. Bag supporter can be adjusted to suit individual operators.



Double weigher, with reversible conveyor.

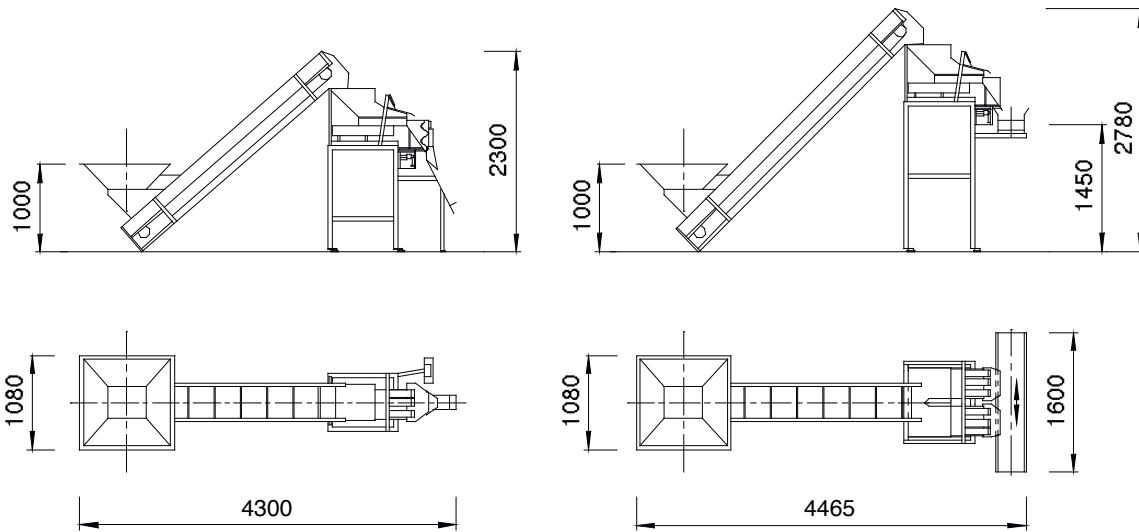

	W-5	Wx2-5
Batch weights, kg	0,5–5	0,5–5
Capacity, batches of 3 kg/min	13–15	26–30
Scales	1	2
Compressed air supply: 3 bar, l/min	25	50
Electrical connections.....	wired for 3-phase N/PE~, 230/400 V, 50 Hz, 16 A	

The machine is fitted with a collecting hopper with a high limit sensor. When products reach the high limit, the sensor halts the feed elevator. The coarse feed continues to vibrate after the damper has closed, in order to increase capacity. Weighers are supplied complete with electronic scales. Scales permit

settings for batch weights, resetting and weight-controlled emptying. Electronic counter for automatic emptying of preset number of batches. An automatic tare system ensures that weight values are always correct even if dirt should happen to fasten on the scales. Emptying is pneumatically con-

trolled via a foot pedal or pushbutton. Machines are available with either single or double scales. The weighers can be connected to any fullautomatic bagging equipment.

Special versions available adapted for other products
Automatic stamping of date and sorting code
In and outfeed conveyors

Återförsäljare: