

Onion peeler



type USM-X100

Operating principle

The Sormac onion peeler USM-X100 combines easy operator use with a good reliability. The operator has within reach a rotating, mounted display panel with all the important functions at their disposal. Also shown is important information like capacity, number of peeled onions, operating hours and malfunction identification.

By means of a singulating chain the onions are transported from the infeed hopper and positioned onto the flights of the transport chain. The operator places the onions in the right horizontal position. The rotating knives top, tail and cutting arms make a horizontal cut around the onions.

At the end of the conveying section the onions are picked up with a double holding-arm system with rotating holders. This arm is fitted on a rotating structure. During the rotating movement the onion spins around its own axis, whereby a cut over the complete circumference is made. The depth of the cut is also adjustable. During the cutting air is blown into the cut to remove the skin.

For adapting the machine to different onion diameters several adjustments are provided. These can mostly be made from outside, even during operation, by means of a hand wheel.

The Sormac air saving technique which is used in the USM-X100, takes care of low energy consumption in combination with a higher peeling quality.

Patent pending

**invest
in
the
future**

sormac bv
vegetable processing equipment



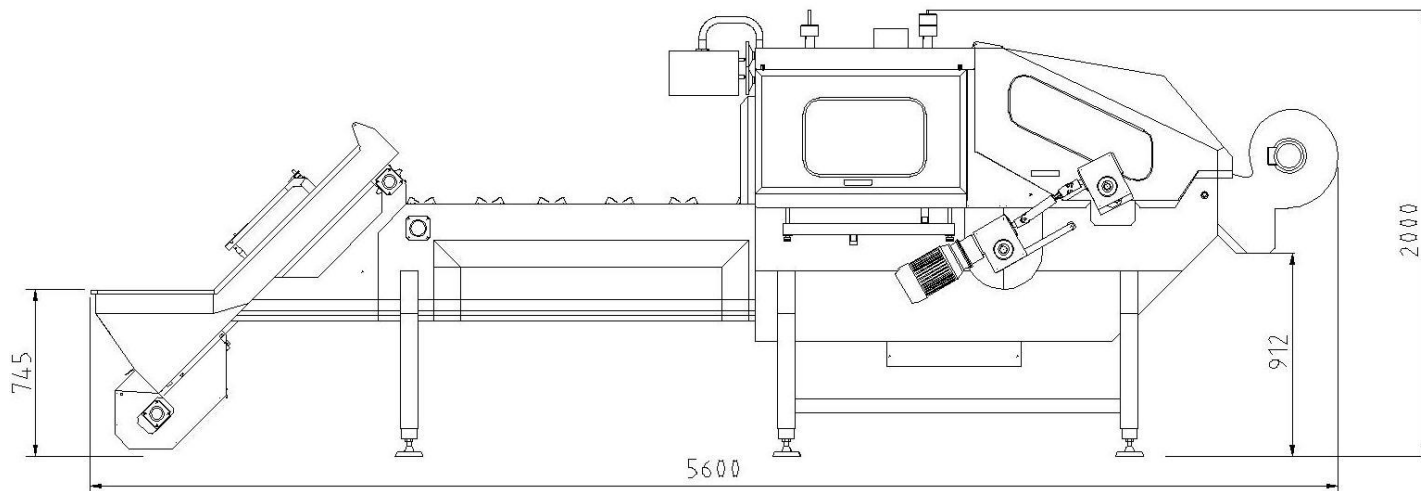

Product specification

The USM-X100 can peel onions with a diameter of 40 – 140 mm, divided in 3 sizes with each own pockets:

- 40 – 60 mm,
- 55 – 110 mm (standard model),
- 80 – 140 mm

Capacity

Depending on diameter, shape and quality the peeler can handle up to 4.800 – 6.000 onions per hour, positioned by one person.

Features

- perfect peeling quality
- complete dry peeling
- high yield (little waste)
- hygienic design (easy to clean and disinfect)
- extremely durable, hard-wearing and reliable
- low energy and air consumption
- ease of access

Options

- Transport chains for different onion grades
- Direct mounted inspection table
- Operators platform

Technical data

Voltage	: 230/400 V, 50/60 Hz
Total installed motor power	: 2,3 kW
Air pressure	: 6 bar (dry air)
Air consumption	: 1,2 Nm ³ /min.
Weight	: ± 750 kg
Dimensions (L x W x H)	: ± 5.600 x 1.150 x 2.000 mm

Alterations reserved

sormac bv
vegetable processing equipment

P.O.Box 419, 5900 AK Venlo, Nederland
Tel.: (+31) 773518444 Fax.: (+31) 773515357

E-mail : info@sormac.nl Internet : www.sormac.nl

