

Roller Table RT

For inspection and manual grading of potatoes, root vegetables etc



RT 500x2000 roller table

Roller tables are designed to rotate and distribute potatoes, root vegetables and other similar products, so that they can be inspected from all angles.

Table construction has been kept low, to ensure ergonomically cor-

rect working stance. Tables are also available with double roller lines with a 200 mm waste and reject funnel between them.

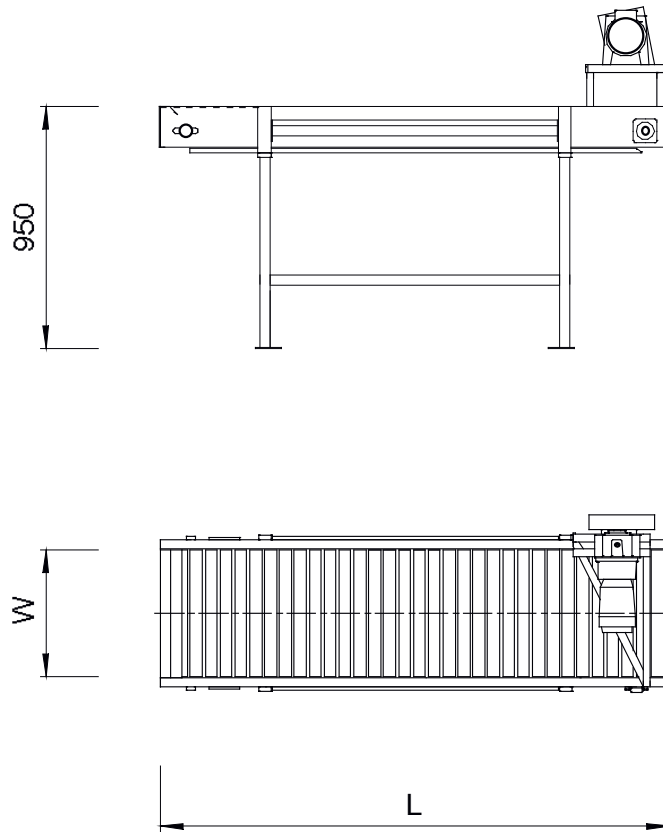

Table width (W), standard versions	400, 500 or 600 mm
Table length (L), standard versions	1500, 2000, 2500 and 3000 mm
Roller	Plastic ø 50 mm
Drive unit	0,37 kW geared motor
Electrical connections	option

Tables are fitted with hatch covers to facilitate cleaning. With a view to preventing collection of vegetable tops etc there is no through shaft at the input end. As option one roller can be with hinged construction to let out

waste on return part. Tables can be manufactured to wide-ranging individual specifications incorporating various platforms, rails, leg units, lighting and reject funnels. Double roller line model RT 2x500x2000 has a 200 mm reject

funnel between the roller lines, and is designed for manning from both sides. Rollers are available in various diameters and materials to suit specific products.

Accessories

- Electrical connections
- Rubber coated rollers
- Rails, storage funnels and leg units
- Other widths and lengths to customers' individual specifications
- Available in stainless steel
- Hinged roller

Aterförsäljare: