

## Bag Presenter BE 5000

For fully automated packaging in 1–10 kg paper bags.

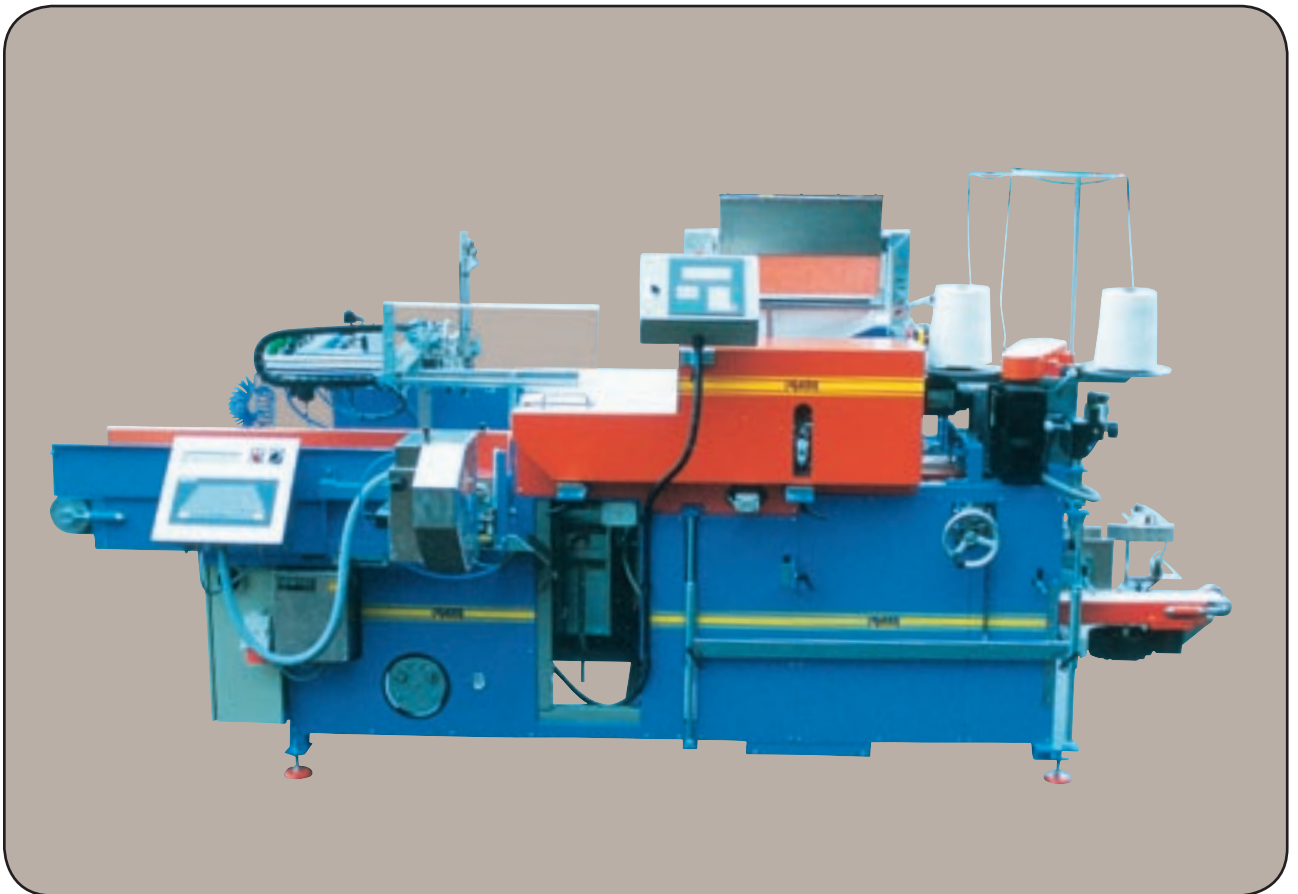

Bag presenter BE 5000

The BE 5000 bag presenter is designed for fully-automated packaging of potatoes, onions or other products in 1-10 kg paper bags either with or without handles. The bag presenter can be connected to electronic scales. Scale batches are emptied into a buffer store to ensure maximum capacity. The bag presenter's magazine will hold approx. 250 bags. Switching over from one size of bag to another is simply carried out with

the help of a system of cranks and levers.

Bags are stamped with dates before they are filled. Defective bags are detected, and halt the machinery.

A powerful vacuum pump ensures optimum bag opening and minimum use of compressed air. Bags are sealed by a sewing machine.

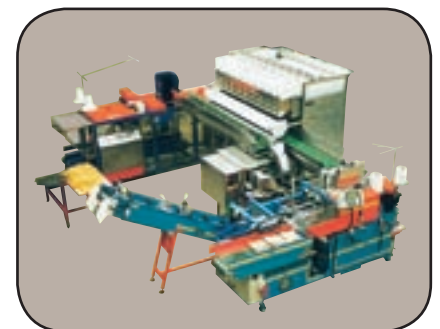

Complete line for paper, net and plastic bags.

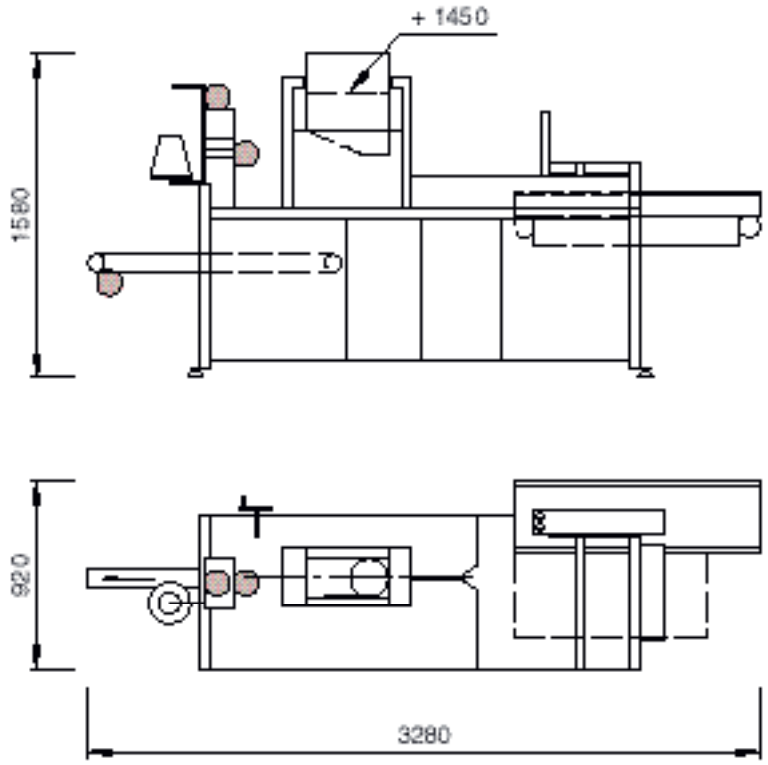

- Capacity ..... 15-20 bags/min (depending on scales, weight, bag opening and bag quality)
- Bag weight ..... 1–10 kg
- Max. bag dimensions L x W x H ..... 260x160x60 mm (+50 mm for handle)
- Min. Bag dimensions LxWxH ..... 170x90x300 mm (+50 mm for handle)
- Magazine capacity ..... approx. 250 bags
- Compressed air supply, free of water ..... min. 6 bar, 600 l/min
- Electrical connections ..... wired for 3-phase N/PE~, 230/400 V, 50 Hz, 16 A

Potatoes can be fed to the bag erector from single, double or computerized scales from either left or right. Equipped with a programmable display for control and trouble shooting. It also includes register for no of bags, kg's, working hours for vacc. pump, sewing machine etc.

Bag sides are folded inwards before bags are fed to the sealing unit. Bag sealing costs are kept low thanks to the use of a specially constructed bag sewing machine that uses a minimum amount of thread. Bags leave in a straight line, or to left or right by a pneumatic bag

pusher. Bag handles should be integrated to ensure optimum machine function. Other models for paperbags are BE 4000 1-5 kg and BE 9000 10-25 kg.

- Various types of scales
- Stamping equipment
- Label printer
- Bag conveyor
- Rotating packing table

Återförsäljare: