

Automatic weigher W 50 LC

For filling of roller containers, octabins and other boxes or sacks



W 50 LC automatic weigher with fall breaker for filling boxes etc

The W 50 LC automatic weigher is a versatile machine for filling different types of box and sack. It is simple to program it to empty multiple batches, one after the other, and thus fill packagings and containers that hold a great deal more than the weigher's scales. The control system combines batches by weight, to avoid un-

necessary surplus in spite of the fact that several batches have been emptied into the packaging or container.

The automatic fall damper receives potatoes and similar products, gently allowing them to fall into the required box.

By reversing the conveyer, the weigher can quickly be adapted for filling sacks in the same way as the ordinary W -50 automatic weigher.



Double boxfilling version.

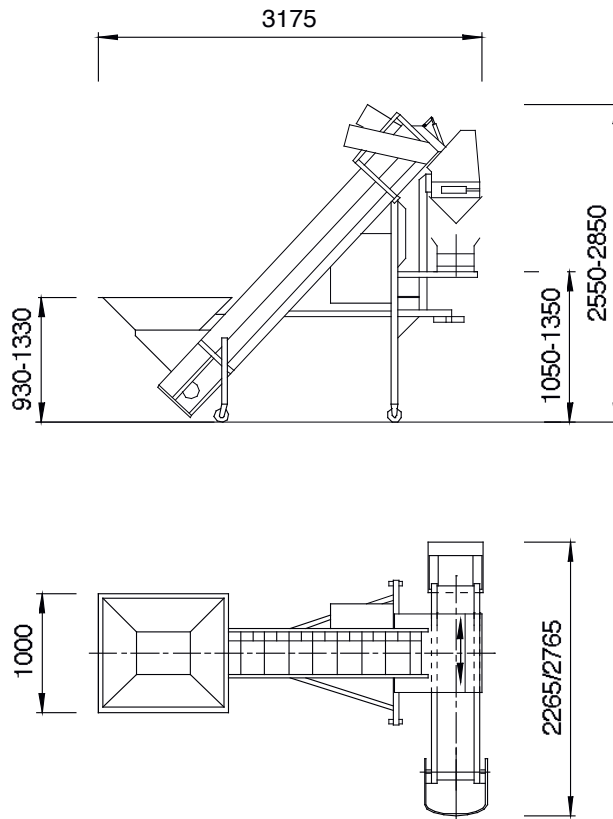

Capacity, 10 kg sacks	5 t/h
Capacity, 200 kg boxes	10-15 t/h
Sack size, potatoes	5-50 kg
Drive unit	2 x geared motors, output 0,37 kW
Reversible conveyor	w = 350, L = 1600/2000 mm
Electrical connections.....	wired for 3-phase N/PEN, 230/400 V, 16 A

The machine is fitted with both coarse and fine feed for rapid but nevertheless accurate batch weighing. The fall breaker makes for careful filling in boxes of potatoes and other similar products. The operator simply enters the batch weight and final weight required. The machine matches

the last batch by reference to the previous batches so that there is no unnecessary surplus. The operator's control panel includes statistics for total weight and number of boxes filled. The weigher can be equipped with two fallbreakers for auto boxfilling.

Auto reversing boxfilling
Available in stainless steel

Återförsäljare: